

**CS LAB** s.c.  
Electronic Laboratory

## POWER MODULE V.2

Power supply module for stepper/servo motor drives (DC/AC/BLDC)  
with soft-start

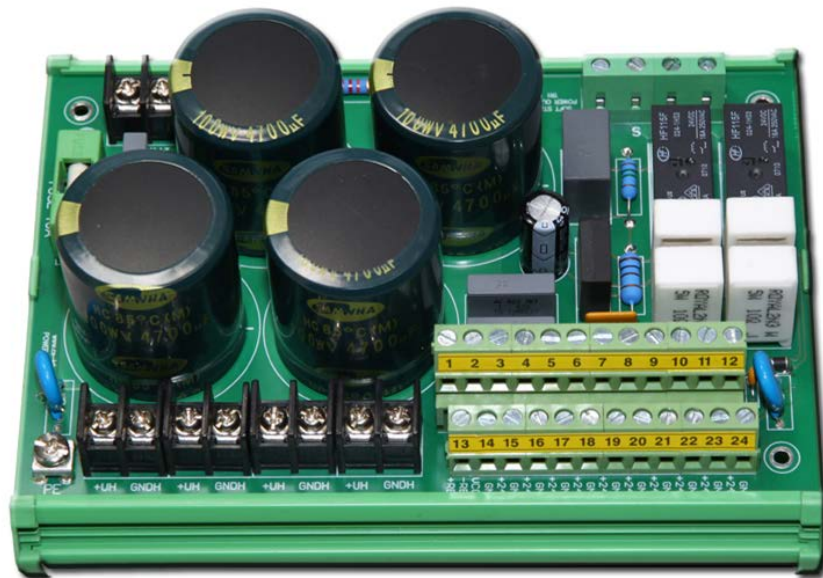

[www.cs-lab.eu](http://www.cs-lab.eu)

© copyright 2013 – CS-Lab s.c.

## Index

<b>1. General .....</b>	<b>3</b>
Signs used in this guide .....	3
<b>2. Product features .....</b>	<b>4</b>
<b>3. Functions of the Power Module.....</b>	<b>5</b>
Soft-Start .....	5
HV Relay .....	5
HV power divider.....	5
HV 16A fuse .....	6
Filtering capacitors .....	6
PE divider.....	6
Capacitors discharge system .....	6
<b>4. Connection scheme.....</b>	<b>7</b>
<b>5. Connection .....</b>	<b>8</b>
Motor drives power circuit connection way – HV power supply .....	8
<b>6. Power Module 325VDC/2000VA efficiency .....</b>	<b>9</b>

## 1. General

In a power circuit of motor drives it is often necessary to use a DC power supply, as drives designed to be as compact as possible do not provide it. Drives shouldn't be powered by pulse-powered systems, there should be linear power supplies with proper filters used, providing supply of suitable constant voltage to the system. The use of high-capacity capacitors significantly decreases ripples generated on the supply line, what actually influences on a system lifespan.

The Power Module v2 is equipped with a number of functions which provide safe and stable work of motor drives. The functions are described in chapter 3.

Power Module v2 is only a power supply module and it requires an external mains transformer and a rectifier bridge. Selection of the transformer and rectifier bridge was described in sections: 6, 7 and 8 of this manual.

The module was equipped with 24V logic power divider. If you want to use it you have to remember to connect to it properly selected 24V DC power supply.

### Signs used in this guide



Useful information, tips



**WARNING!**

Failure to comply with these warnings may lead to inappropriate functioning or damage of the device



**HIGH VOLTAGE!**

Potential danger and/or possible injury risk

---

## 2. Product features

The Power Module 325VDC/2000VA has three input voltage versions: up to 100VDC, 150VDC, 200VDC. This results from capacitors used, which can be damaged if the voltage is exceeded. The table below shows the module operation parameters for all three versions.

PARAMETER		VALUE		
		PowerModule v2 100VDC	PowerModule v2 150VDC	PowerModule v2 200VDC
<b>UAC<sub>TR</sub></b>		60VAC	90VAC	120VAC
<b>UHV<sub>REC</sub></b>		85VDC	127.5VDC	170VDC
<b>UHV<sub>MAX</sub></b>		100VDC	150VDC	200VDC
<b>Continuous Output Current</b>		10A	6,6A	5A
<b>Peak Output Current</b>		20A	13,2A	10A
<b>Continuous power</b>		1000VA		
<b>Peak power</b>		2000VA		
<b>Operation temperature</b>		0oC TO +60oC		
<b>Relative humidity</b>		10% do 95% (without condensation)		
<b>Weight</b>		0,55kg		
<b>Dimension</b>	<b>High</b>	90mm		
	<b>Width</b>	125mm		
	<b>Depth</b>	162mm		

UAC<sub>TR</sub> – output (alternating) voltage of a transformer - secondary winding voltage.

UHV<sub>REC</sub> – Recommended output voltage (constant) of the power module

UHV<sub>MAX</sub> – Max. output voltage (constant) of the power module

### 3. Functions of the Power Module

The power supply module is equipped with several functions needed for safe use and correct work of motor drives:

#### Soft-Start

It's a system that provides soft activation of a mains transformer. Thanks to it there will be no inrush current surge in mains electricity circuit what protects you against turning off or blowing mains fuse. The Soft- Start system mounted in the power module is for activation of transformers with power not larger than 1000VA! The Soft-Start system is fully automatic and it doesn't require any control of.

#### HV Relay

The relay activates or deactivates 230V AC mains electricity. Thanks to it a software that controls a machine (Mach3, Mach4) can switch on or off motor drives' power supply anytime it's needed. Pin terminals that control the HV relay were placed on a green terminal connector and described as „REL+” and „REL-”.

If a Power Module v2 works with a CSMIO/IP controller you can use „HV Enable output” signal to control the HV relay. „HV Enable output” signal settings are available in plugin (see the next page scheme). The function is hardware supported by CSMIO/IP and in case of alarm state the HV relay is switched off in 1ms and the same motor drives power supply is cut off.

#### 24V DC power divider

The other pins in the green terminal were used for 24VDC power divider. The divider is equipped with reusable non-replaceable polymer fuse 2A activation value. The pin signed as „VCC” is the 24V DC power supply input, the „+24V” sign are 24V DC power outputs (see the picture). **Należy pamiętać, że łączne obciążenie wszystkich wyprowadzeń powinno być nie większe niż 2A (ze względu na użyty bezpiecznik).**

#### HV power divider

For safety, aesthetics and mainly for easy install the power module is equipped with an HV power divider. The divider has separate connectors for four motor drives. The divider pins are described as „HV+” and „HV-”.

## HV 16A fuse

It is a 16A fuse which task is to cut motor drives power supply off if the power module is overloaded or if there is a short in motor drives power supply circuit.

## Filtering capacitors

The power module is equipped with six high-capacity capacitors which task is to reduce ripple of motor drives power voltage. Additionally the capacitors store energy recovered during motors braking.

## PE divider

Besides the HV divider the Power Module 325VDC/2000VA has a divider for PE conductor. PE pins are placed with „HV+” and „HV-” pins. It's for easier electrical installation. If there are significant noises it's recommended to use PE dividers and to lead PE wiring directly to a main PE connector (look at the scheme).

## Capacitors discharge system

High-capacity capacitors used in the Power Module 325VDC/2000VA can store significant amounts of electrical energy for a very long time. This creates a risk of electric shock or short circuit during servicing operations. For this purpose the Power Module 325VDC/2000VA is equipped with a capacitors discharge system which is switched on after control signal on PK+ and PK- is off.

A Power Module 325VDC/2000VA has another one function, namely - using a common power supply for many motor drives allows for recovering significant amounts of electrical energy and also the power supply is not that loaded. It's because braking servo motor works like electric generator. The electric energy generated during braking is immediately used by other servo motors. If the energy wasn't used at once is stored in capacitors for later use.

## 4. Connection scheme

Here is a sample scheme of the power supply module connection including 24VDC Power Divider.

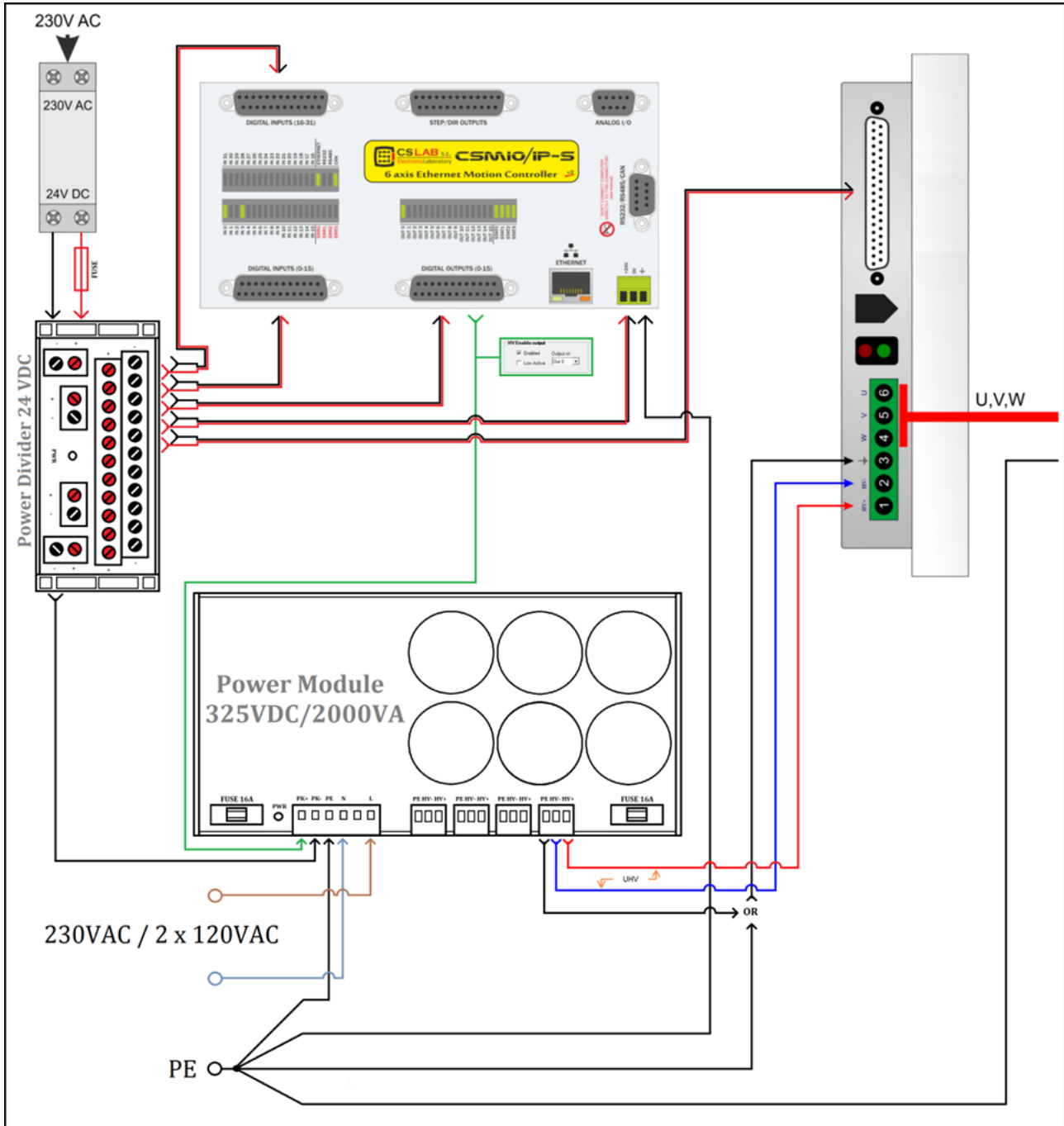

If you do not have one phase 230VAC voltage and you want to use two 120VAC phases - one of the phases connect to N terminal and the second one to L.

## 5. Connection



The power module connection was limited to only few easy activities but there can be no mistake during the connection and you have to remember to not perform the connection under voltage and exercise extreme caution during the first run.

### Motor drives power circuit connection way – HV power supply

- 1) Connect 230VAC power voltage to „N” terminals (0V – neutral) and „L” (230V AC – phase ).  
If you not have one phase voltage 230VAC and you want to use two 120VAC phases - connect one of the phases to N terminal and the second one to L.
- 2) Connect the PE to „PE” terminal.
- 3) Motor drives should be connected to „HV+” terminals (positive pole), „HV-” (negative pole) and „PE” (protective conductor).
- 4) It's necessary to supply the HV relay (PK+ and PK- terminals). The relays should be controlled by safety circuit of a control system or special-purpose signal. In CSMIO/IP controllers it's „HV Enable output” signal.



Before the first run!

During connection pay attention to cross section of connection cables you use.

„PK+” and „PK-” are separated from other terminals of a Power Module 325VDC/2000VA.

It's not allowed to connect „HV+” and „HV-” with „N”, „L” and „PE” - this would cause short circuit and potential damage of a Power Module 325VDC/2000VA.

The Power Module 325VDC/2000VA” is a transformerless power supply and output voltage  $U_{HV_{OUT}}$  is not separated from input voltage  $U_{AC_{IN}}$ .

## 6. Power Module 325VDC/2000VA efficiency

The Power Module 325VDC/2000VA is adapted to supply:

- max. 4 x 750W servo drives: [simDrive™AC Servo 750W 325V \\*\\*Model M4-H075K](#)
- max. 6 x 400W servo drives: [simDrive™AC Servo 400W 325V \\*\\*Model M4-H040K](#)



### HIGH VOLTAGE !

When AC input supply is connected there is a high voltage on the power supply system. Installation, launching and conservation should be done by qualified staff. Installation, launching and conservation done by unqualified persons may lead to serious injuries or death.



### WARNING !

The power module contains high-capacity capacitors, which remain charged after AC power disconnection even for 5 minutes.