

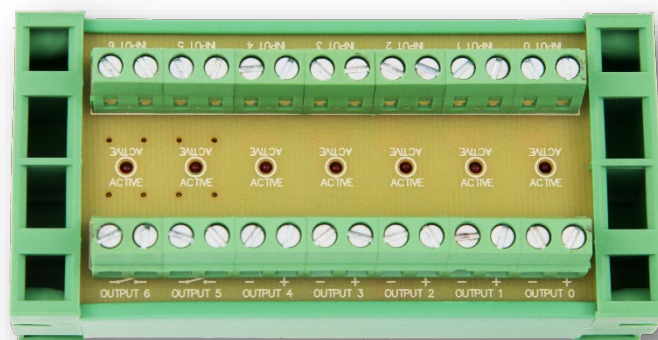

# UNIVERSAL CONVERTER OF DIGITAL SIGNALS WITH OPTO-ISOLATION

*input voltage 5V or 24V*



## 1. Application

Converter of digital signals by CS-Lab s.c. company has three main applications, namely it may serve as:

- galvanic separation system
- voltage adjustment system
- polarization reversing system of control signal

The converter is equipped with very comfortable screw connectors - „ARK” and red diodes signaling the presence of input signals. All closed in a housing which allows for easy mounting on a DIN rail.

As you can see in the picture above the converter has six (6) inputs and six (6) outputs what provides six (6) separate channels. Four (4) channels were built basing on opto-isolators with max. collector current 30mA and max. permissible voltage of collector - emitter 30V. Max. frequency for the opto-isolator is 10KHz. The other two (2) channels were built basing on NO relays with permissible current: 50mA and max. permissible working voltage: 30V.

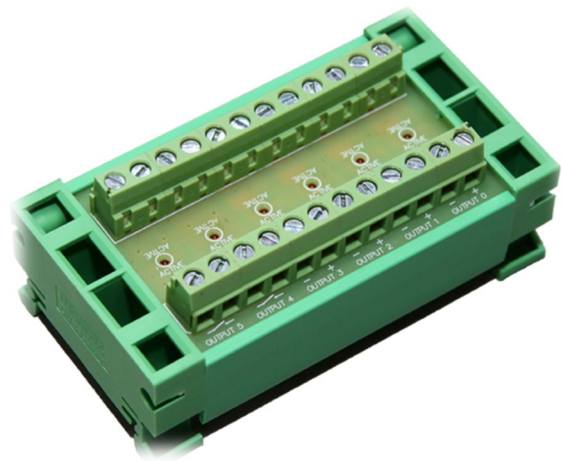

### DIMENSION:

Length: 95mm

Width: 45mm

Total height: 35mm

Height from a DIN rail: 28mm

## 2. Converter types

There are two versions of the converter: 5V and 24 V. The division is only for input signals. You can find both types of the converter in our online store as two separate products. So, you need to know what input signal voltage the converter should cooperate with (include this information if you order via e-mail).

Input current for 5V version:

- opto-isolator inputs 13mA,
- relay inputs 32mA,

Input current for 24V version:

- opto-isolator inputs 7mA,
- relay inputs 19mA.

Output signal voltage depends only on power supply voltage used by mechanist, but it should not exceed 30V.

## 3. Construction of the converter

In the scheme below you can see the converter construction.

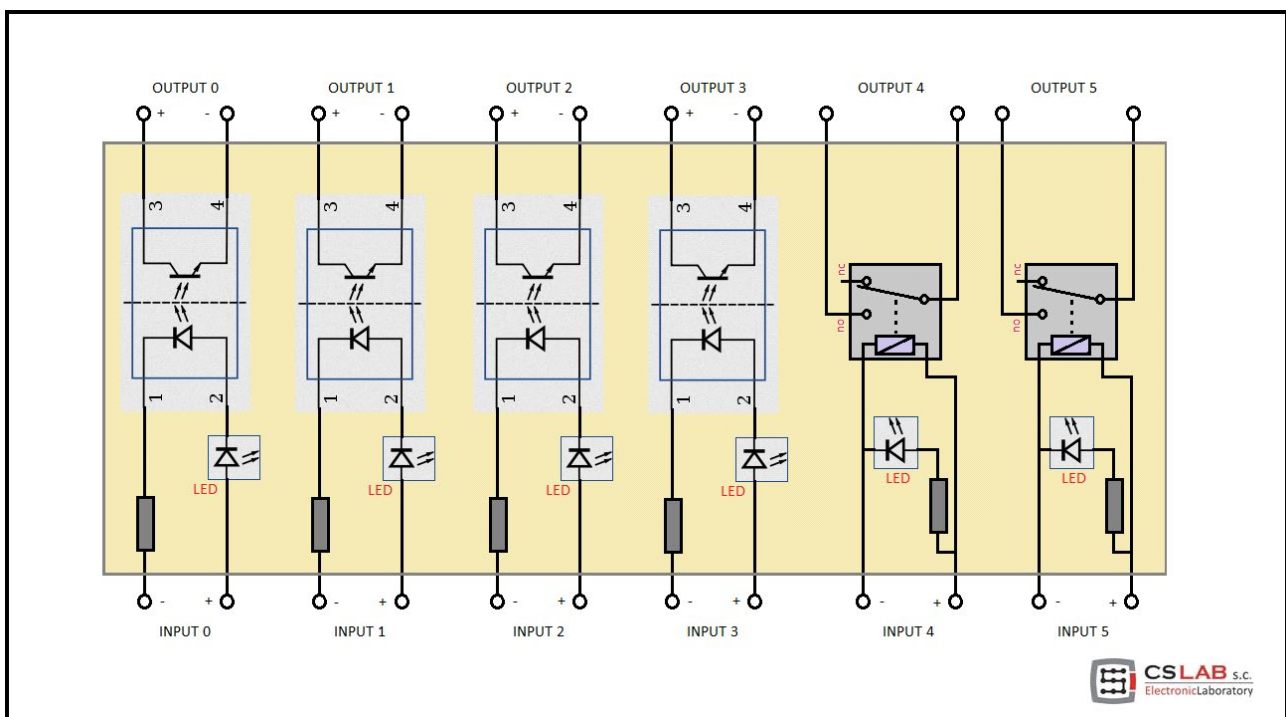

### 3.1 Inputs

As you can see in the scheme there is inputs polarization signed, it is very important to keep this polarization to assure the proper work of converter. In case of wrong polarization, a channel will be not working and what is very important - no internal elements will be damaged.

### 3.2 Outputs

There is no need to describe channels outputs on the relays. As you can see in the scheme there is only NO contact.

Channels outputs built on opto-isolators should be treated like NPN transistor and polarize the emitter - collector connector as described in the scheme to keep current flow direction in accordance with emitter arrow.

## 4. Examples of converter connections

### 4.1 Converter type: 24V

#### 4.1.1 Galvanic separation system

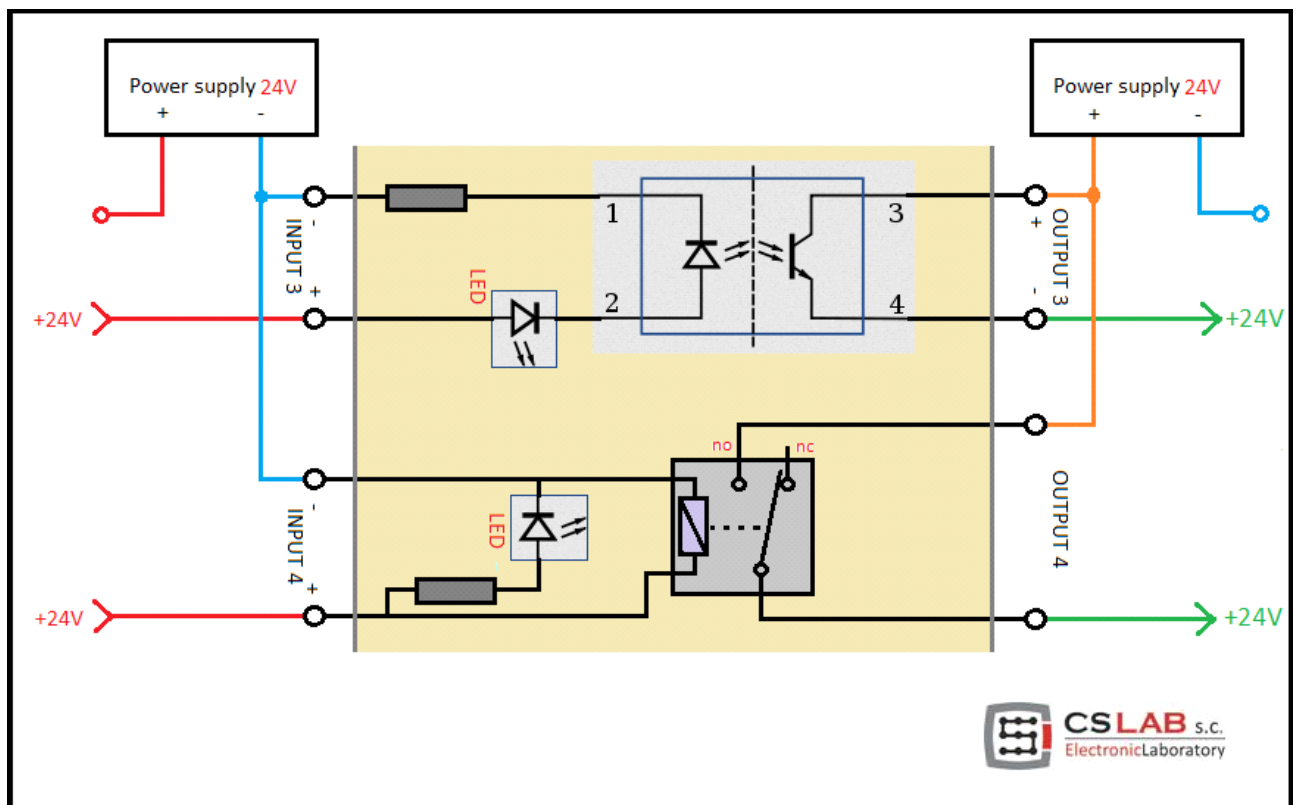

#### 4.1.2 Voltage adjustment system

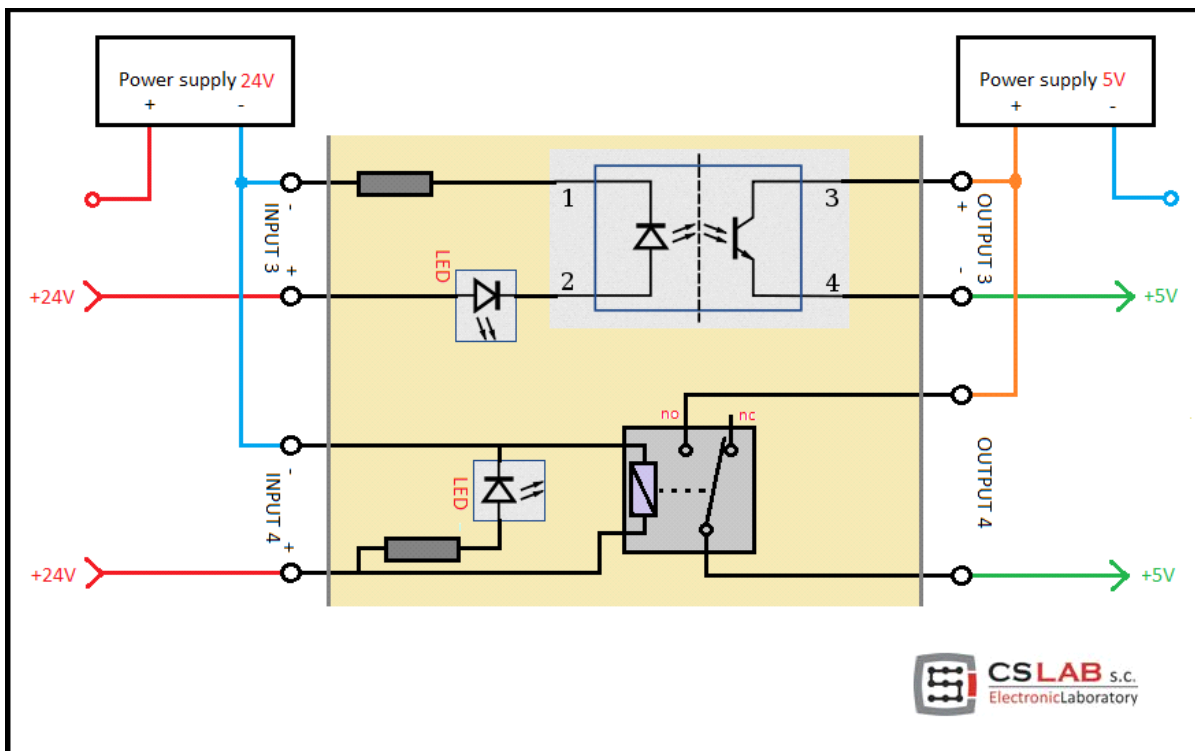

#### 4.1.3 Polarization reversing system of control signal

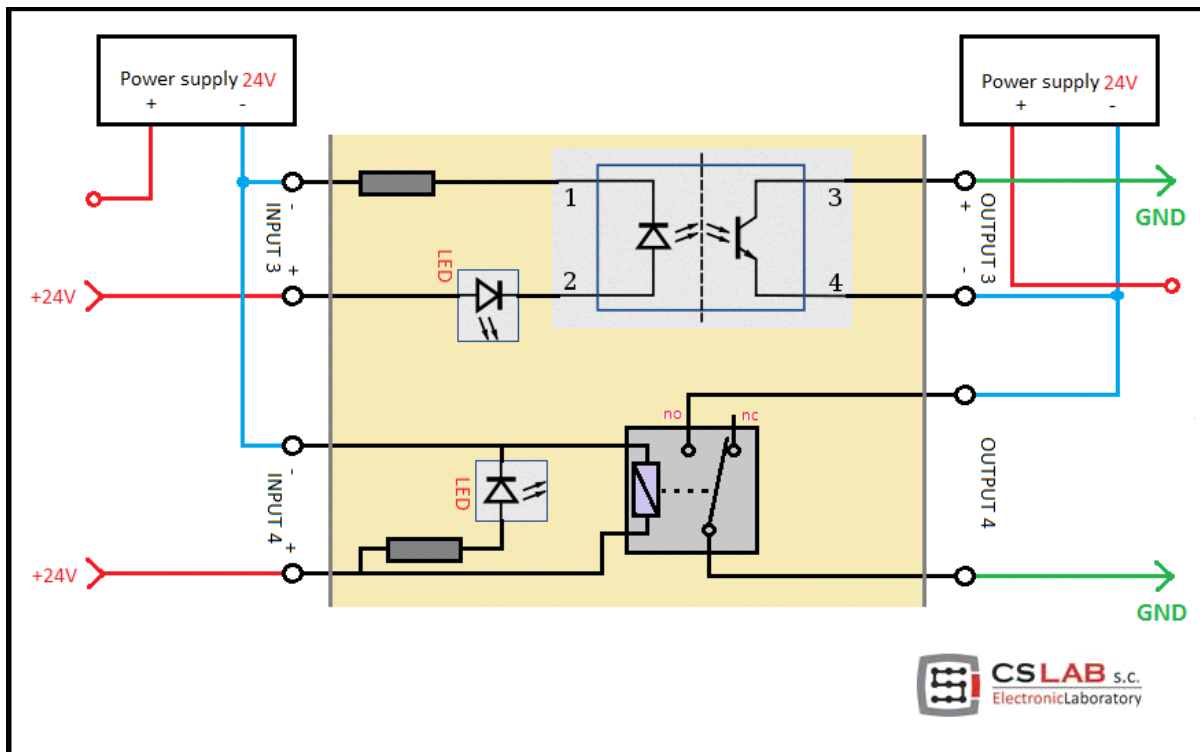

## 4.2 Converter type: 5V

### 4.2.1 Galvanic separation system

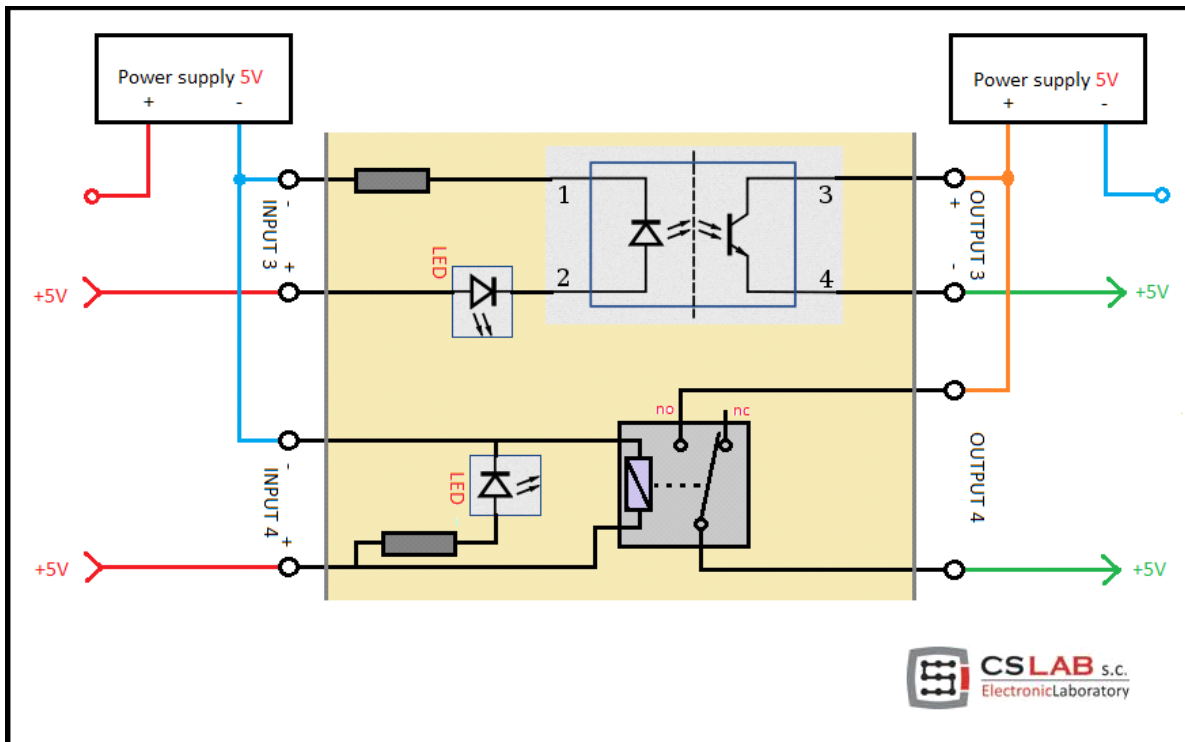

### 4.2.2 Voltage adjustment system

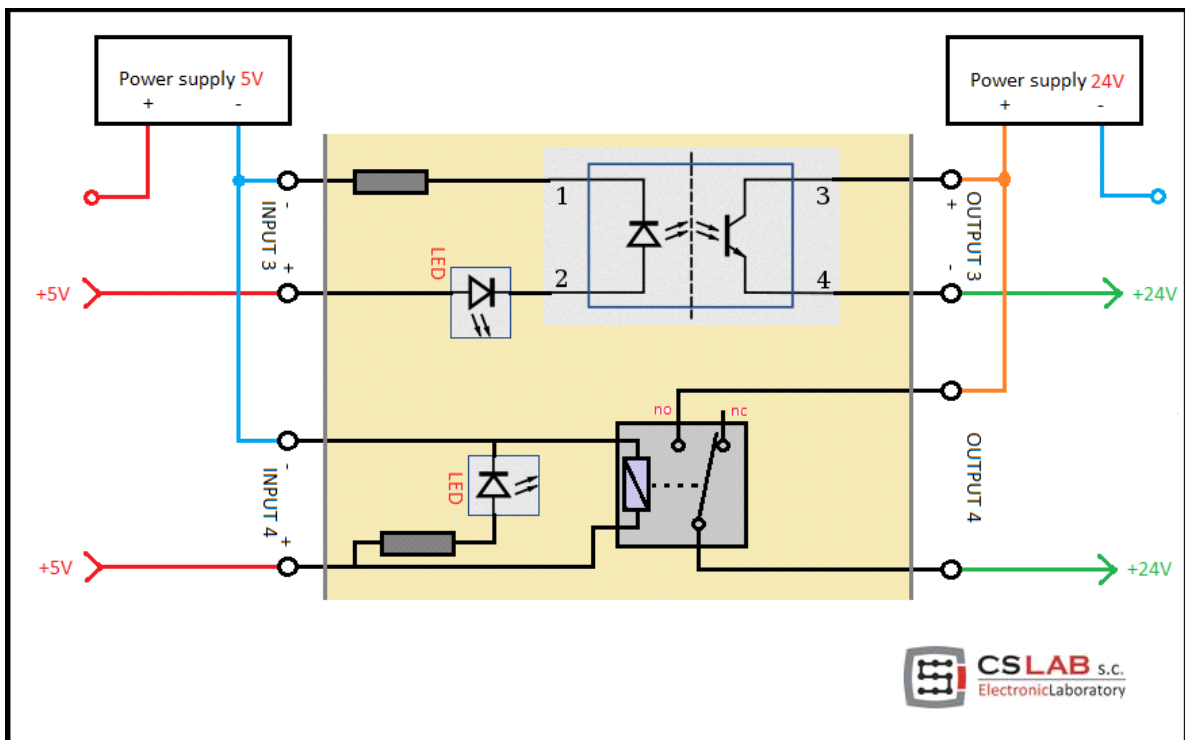

### 4.2.3 Polarization reversing system of control signal

