

 **simDrive**
AC SERVO V2



Applies to hardware version: V2 (750W, 400W)

Applies to firmware version: V2.00

Rev.1.0

Content

1. What's new in simDrive V2?	3
1.1 Signals in DB25 socket - control signals	4
1.2 Signals in DB 15 socket - encoder signals	5
2. Standard encoder cable (5m)	6
2.1 Connection of the standard encoder cable.	6
2.2 Standard encoder cable construction.....	7
3. Standard power cable (5m)	8
3.1 Connection of the standard power cable	8
3.2 Standard power cable construction.....	9
3.3 Power supply connection to simDrive when using standard power cable (5m).	10
4. Connection of simDrive and a motion controller	11
5. Standard brake cable (5m)	12
5.1 Connection of a standard brake cable	12
5.2 Construction of a standard brake cable.....	13
5.3 Connection of a brake relay	14
5.4 Connection of Omron G2RV-SL701 brake relay.....	15
6. Encoder cable longer than 5m	16
6.1 Shielding of an encoder cable longer than 5m	17
7. Power cable longer than 5m	18
7.1 Shielding of a power cable longer than 5m	19
7.2 Power supply connection to simDrive when using a power cable longer than 5m	20
8. CAN bus	21
9. Terminals panel – not-shielded power cable.	22
10. Terminals panel – shielded power cable.	23
11. Accessories – simDrive	24
11.1 simDrive V2 400W.....	24
11.2 simDrive V2 750W.....	Błąd! Nie zdefiniowano zakładki.



1. What's new in simDrive V2?

The new simDrive V2 differs from the previous version.

The new model was equipped with two signal sockets:

- DB25- control signals (Step/Dir, Servo Alarm, Servo Reset, Servo On)
- DB15- encoder and Hall sensors signal.

This change brought two significant benefits:

- much easier and faster connection of control signals
- fully compatible system of simDrive V2 servo drivers and CSM motors with cables.

simDrive V2 (400W/750W)

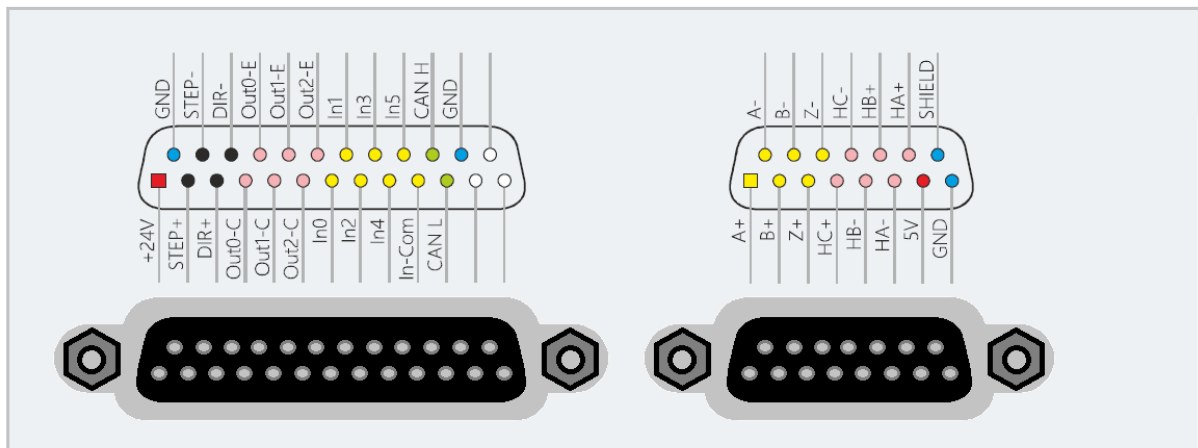

DB25

DB15

1.1 Signals in DB25 socket - control signals

simDrive V2 400W/750W

Control signals

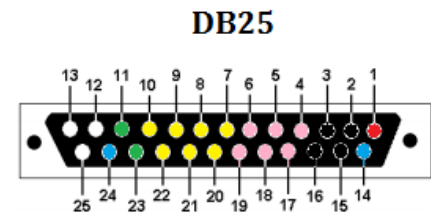

Pin number	Signal	Description
■ 1	+24V	Logic power supply (24V DC)
● 2	STEP+	Step signal (positive input of an optocoupler)
● 3	DIR+	Direction signal (positive input of an optocoupler)
○ 4	Out0–C	Digital output 0 (Collector) <i>[Alarm]</i>
○ 5	Out1–C	Digital output 1 (Collector) <i>[# Homing - output]</i>
○ 6	Out2–C	Digital output 2 (Collector) <i>[Brake]</i>
● 7	In0	Input 0 <i>[# Homing - input]</i>
● 8	In2	Input 2 <i>[Reset]</i>
● 9	In4	Input 4
● 10	In–Com	Common inputs pin
● 11	CAN L	CAN bus (L)
○ 12		
○ 13		
● 14	GND	GND (0V) of logic power supply
● 15	STEP-	Step signal (negative input of an optocoupler)
● 16	DIR-	Direction signal (negative input of an optocoupler)
○ 17	Out0–E	Digital output 0 (Emitter) <i>[Alarm]</i>
○ 18	Out1–E	Digital output 1 (Emitter) <i>[# Homing - output]</i>
○ 19	Out2–E	Digital output 2 (Emitter) <i>[Brake]</i>
● 20	In1	Input 1 <i>[Servo ON]</i>
● 21	In3	Input 3
● 22	In5	Input 5
● 23	CAN H	CAN bus (H)
● 24	GND	GND (0V) for CAN signals
○ 25		

1.2 Signals in DB 15 socket - encoder signals

simDrive V2 400W/750W Encoder signals

DB15

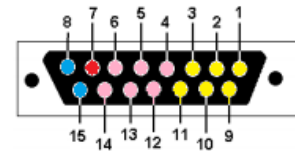

Pin number	Signal	Description
1	A+	Encoder A (+) Input
2	B+	Encoder B (+) Input
3	Z+	Encoder Z (+) Input
4	HC+	HALL sensor C (+) Input
5	HB-	HALL sensor B (-) Input
6	HA-	HALL sensor A (-) Input
7	+5V	5V Output for encoder and HALL sensors power supply
8	GND	GND (0V) of encoder and HALL sensors
9	A-	Encoder A (-) Input
10	B-	Encoder B (-) Input
11	Z-	Encoder Z (-) Input
12	HC-	HALL sensor C (-) Input
13	HB+	HALL sensor B (+) Input
14	HA+	HALL sensor A (+) Input
15	SHIELD	SHIELD

2. Standard encoder cable (5m)

2.1 Connection of the standard encoder cable.

STEP 1. Connect the encoder cable to simDrive V2.



STEP 2. Connect the encoder cable to a servo motor.



2.2 Standard encoder cable construction

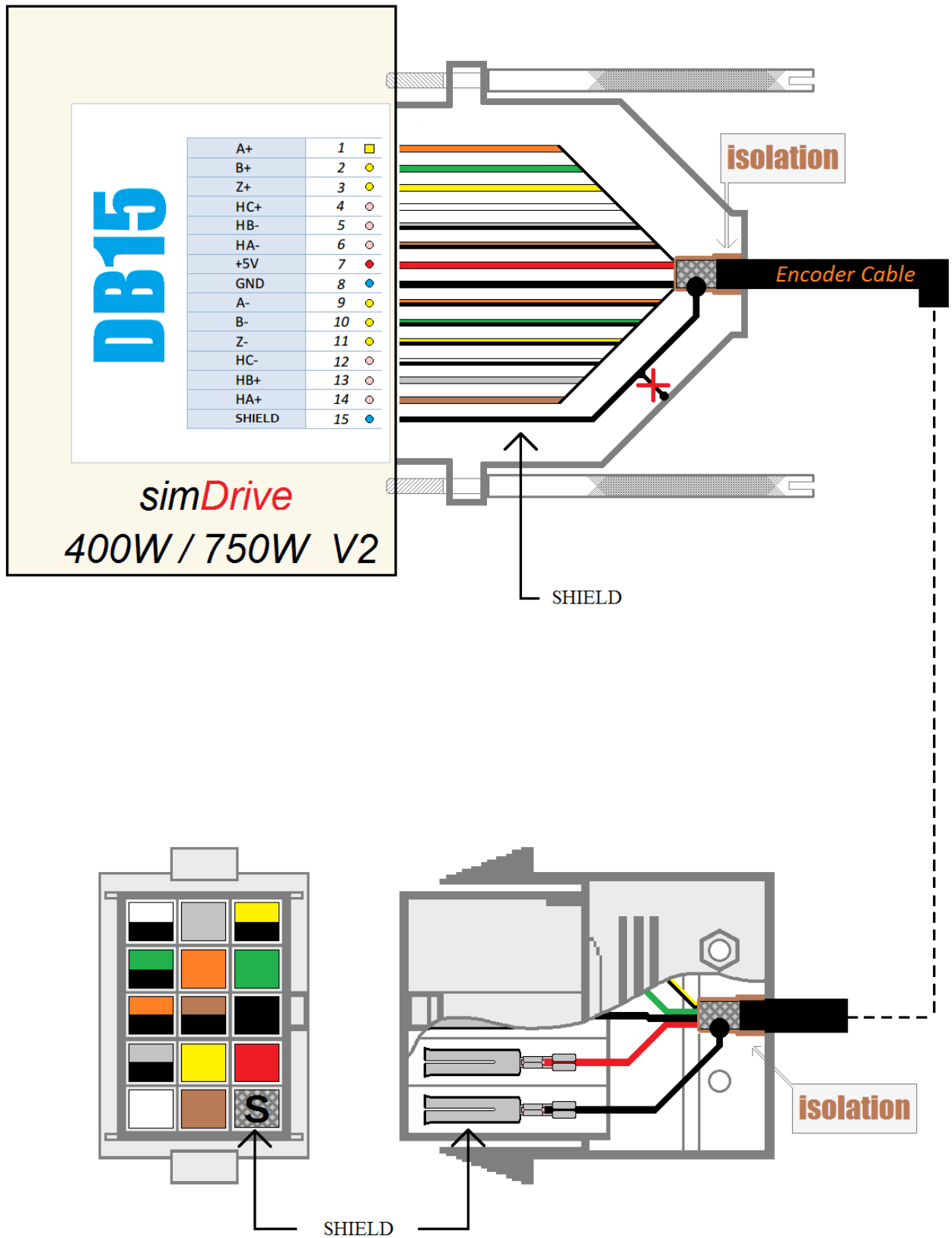

3. Standard power cable (5m)

3.1 Connection of the standard power cable

STEP 1. Connect the power cable to simDrive V2.

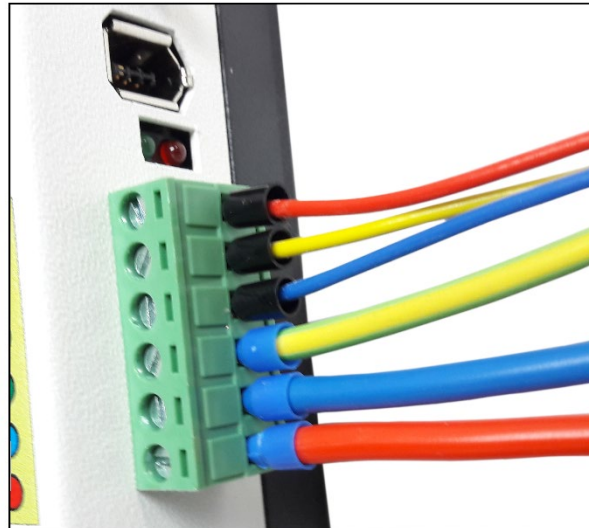

STEP 2. Connect the power cable to a servo motor.

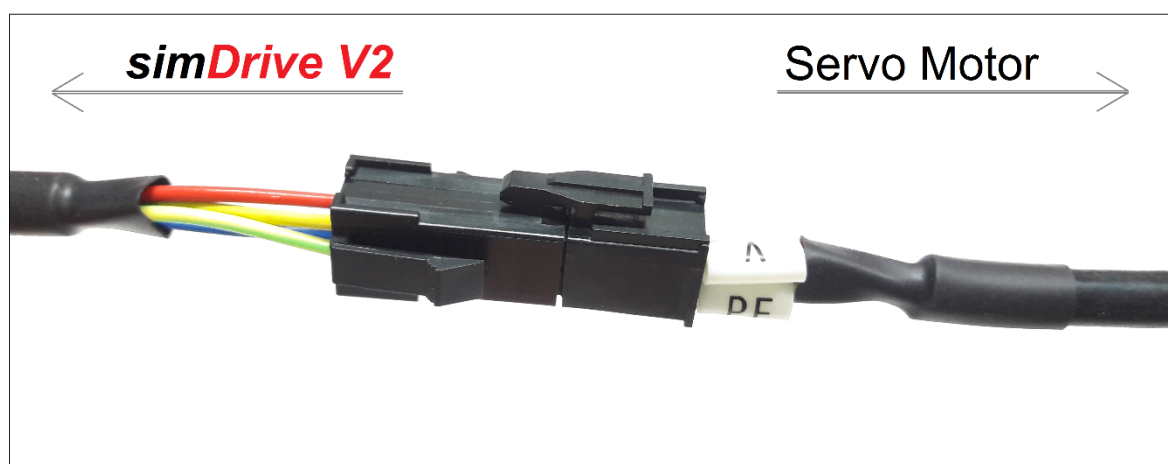

3.2 Standard power cable construction

Power cable not longer than 5 meters doesn't require shielding as the level of interference generated by them is acceptable. If the servo driver is used in industrial environment that requires especially low noise level it's recommended to use shielded power cable regardless of its length.

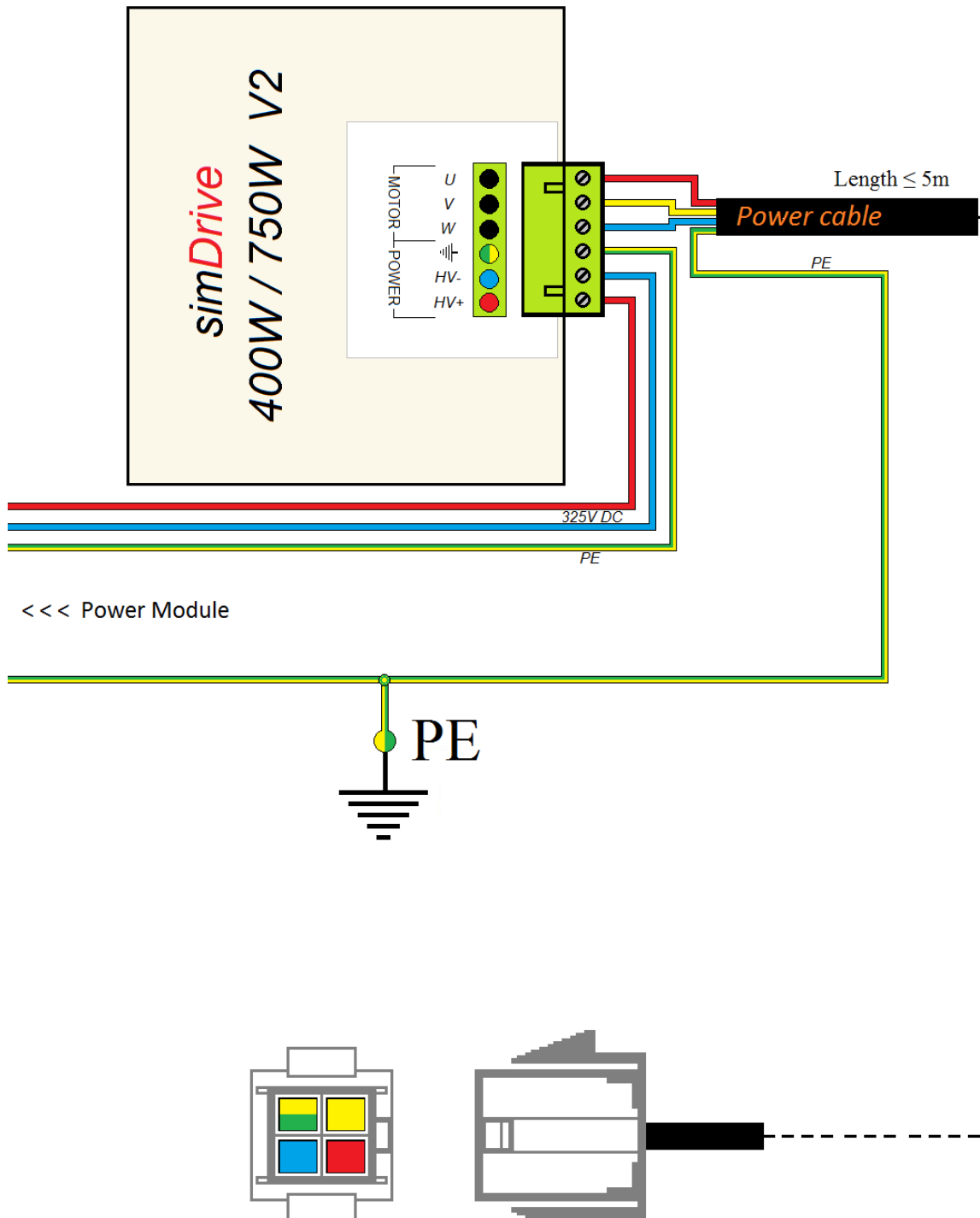

3.3 Power supply connection to simDrive when using standard power cable (5m).

It is recommended to connect PE wires of the power cables with separate wires to a main ground point. This solution will help you to reduce interference faster and more effectively.

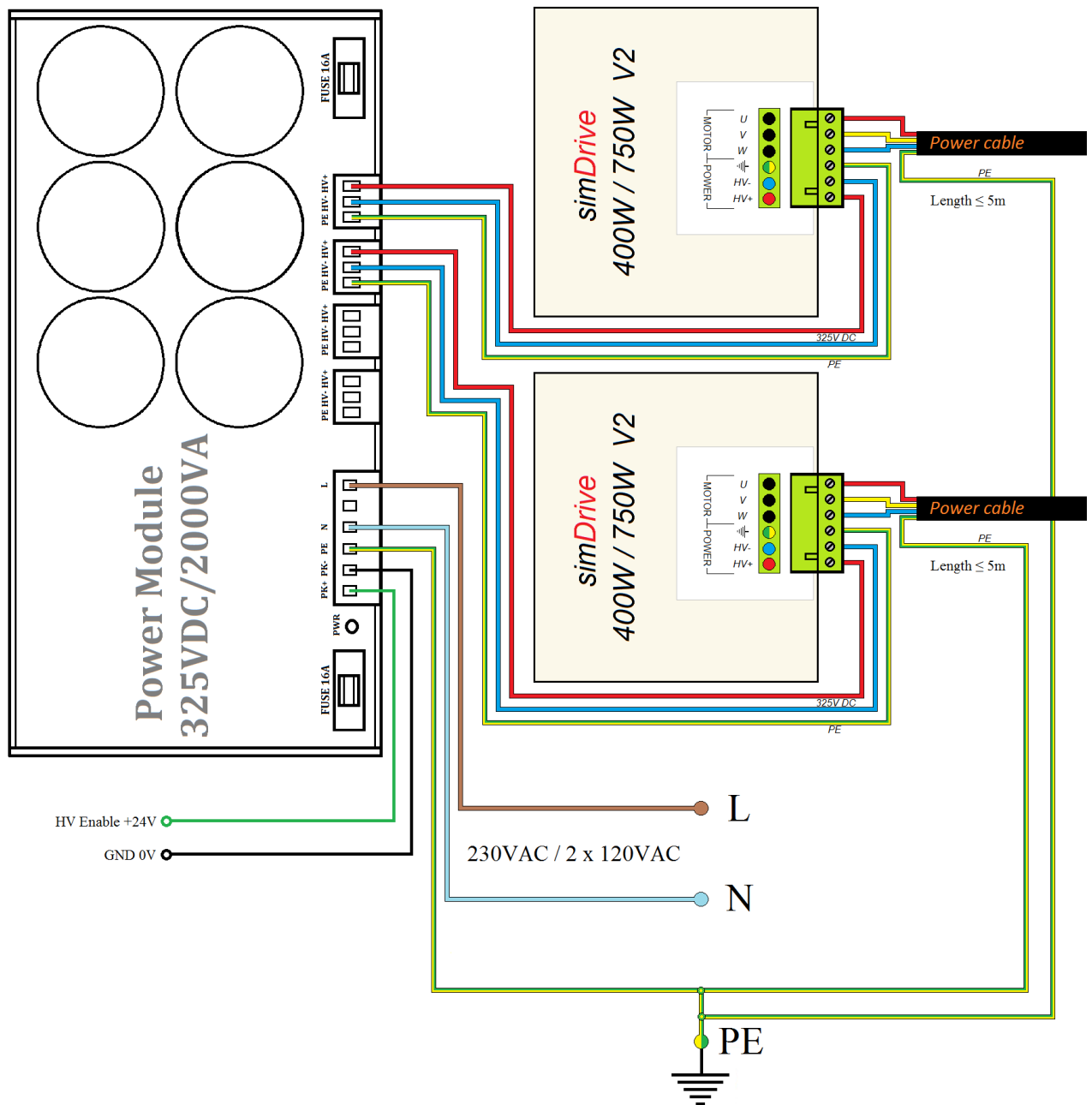

4. Connection of simDrive and a motion controller

The drawing presents the recommended way of connection compatible with the factory simDrive configuration.

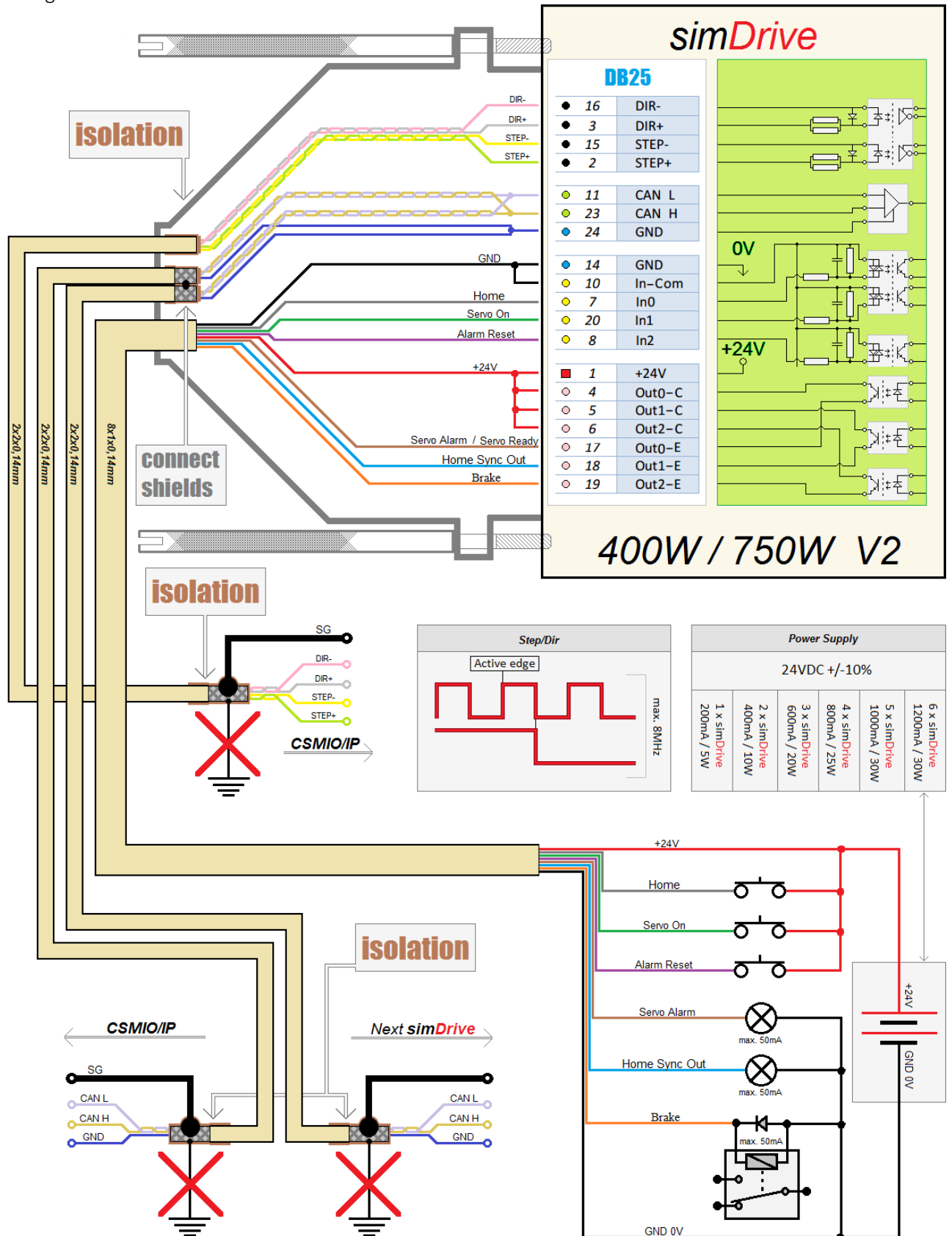

5. Standard brake cable (5m).

5.1 Connection of a standard brake cable

STEP 1. Connect the brake cable to a servo motor.

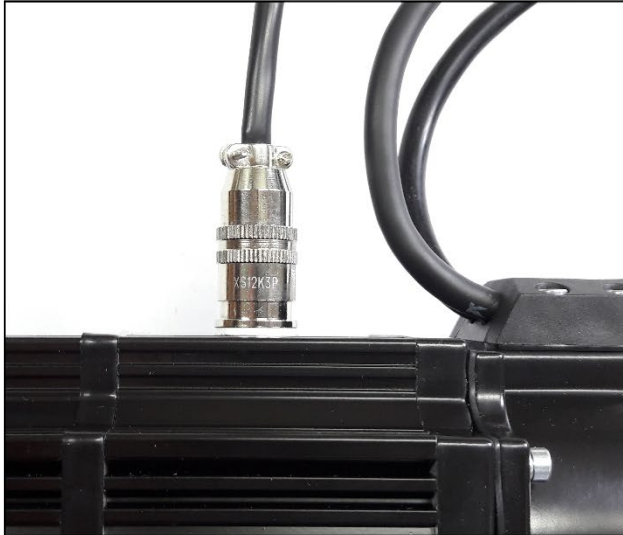

STEP 2. Connect the brake cable to a relay.

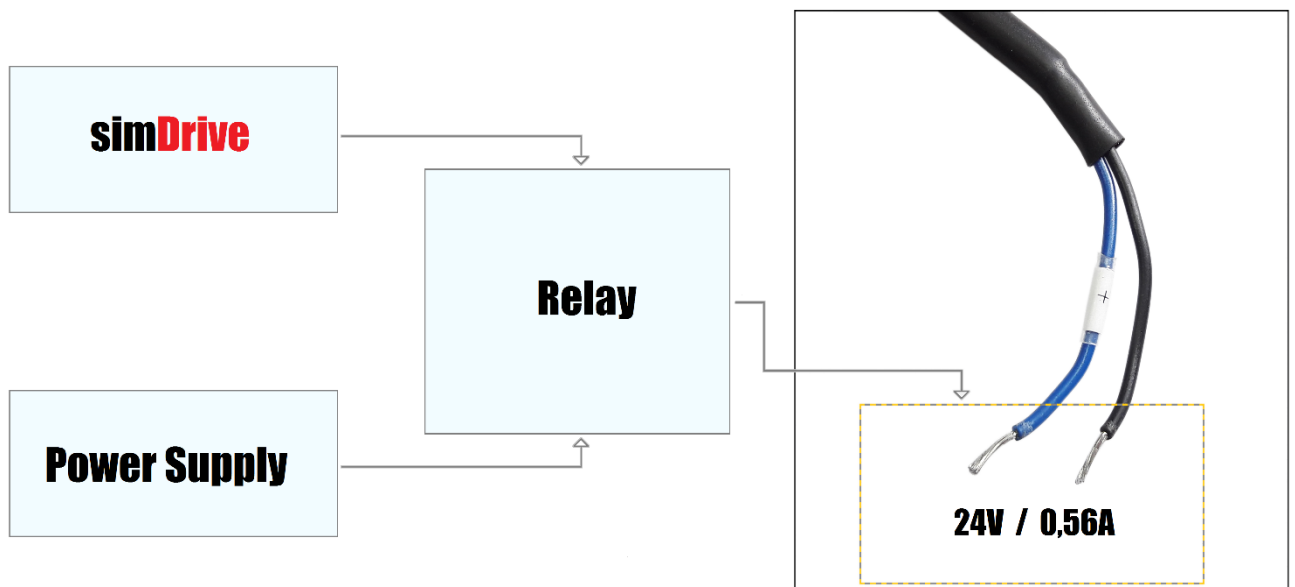

5.2 Construction of a standard brake cable

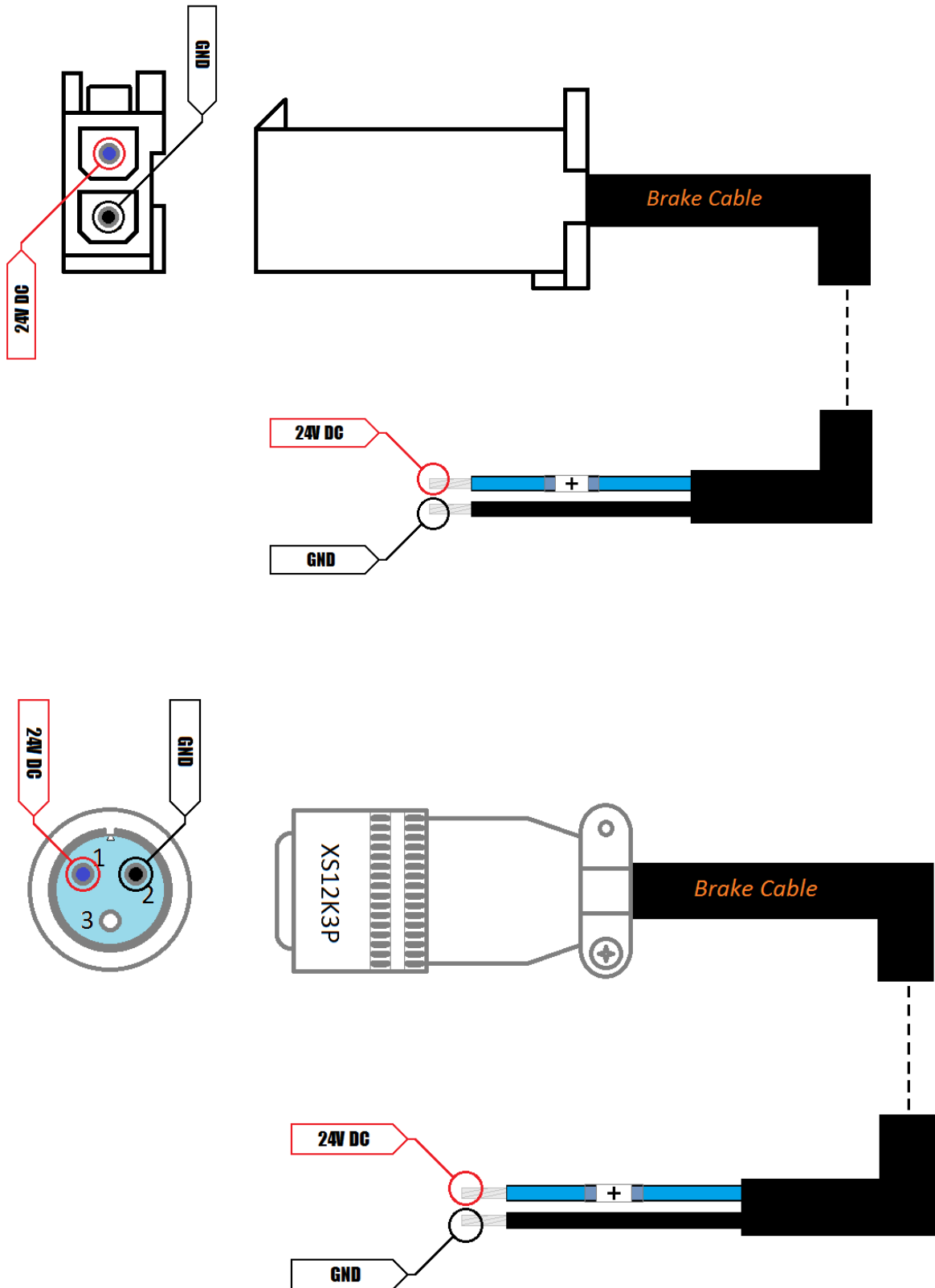

5.3 Connection of a brake relay

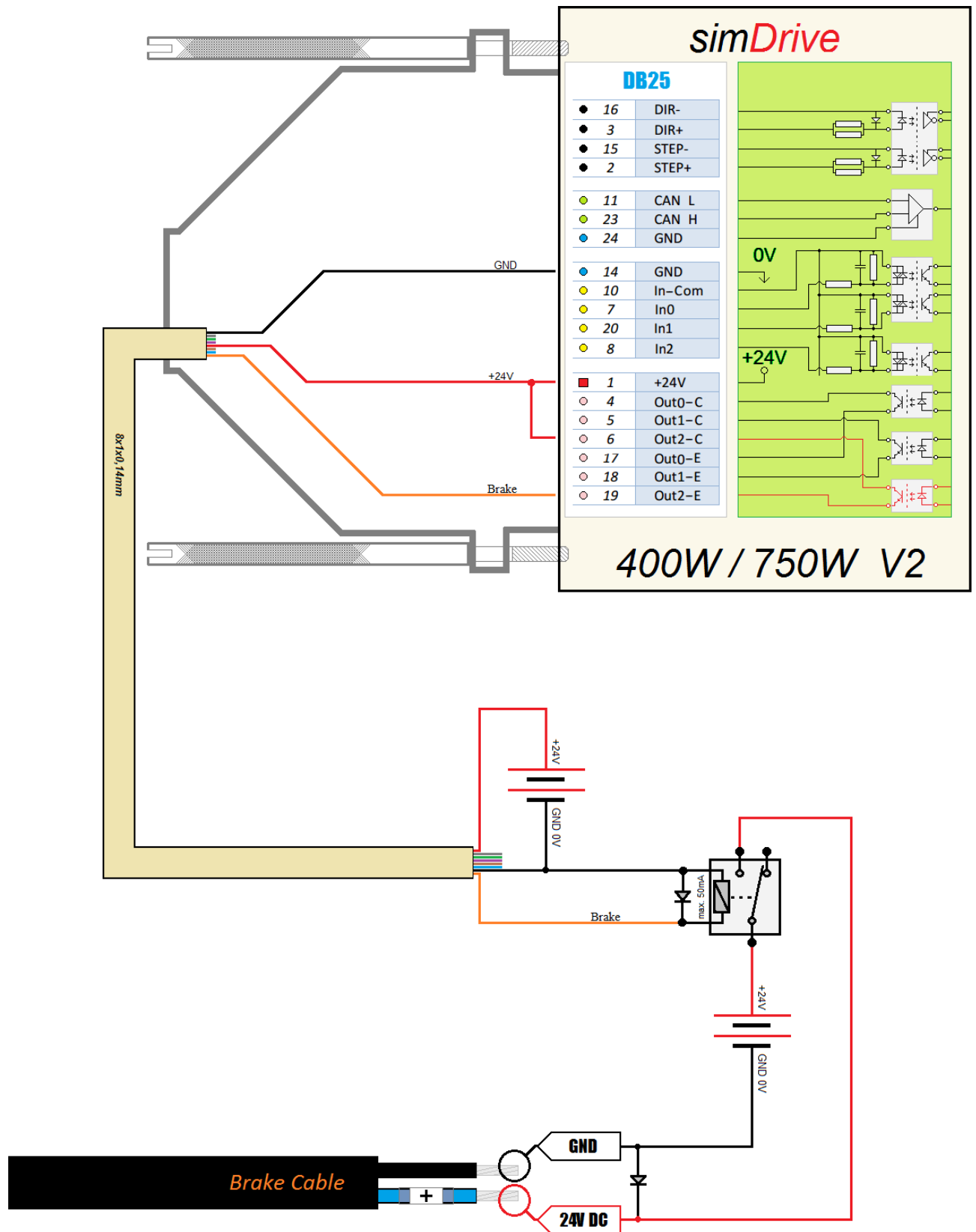

5.4 Connection of Omron G2RV-SL701 brake relay

(Available on CS-Lab's offer)

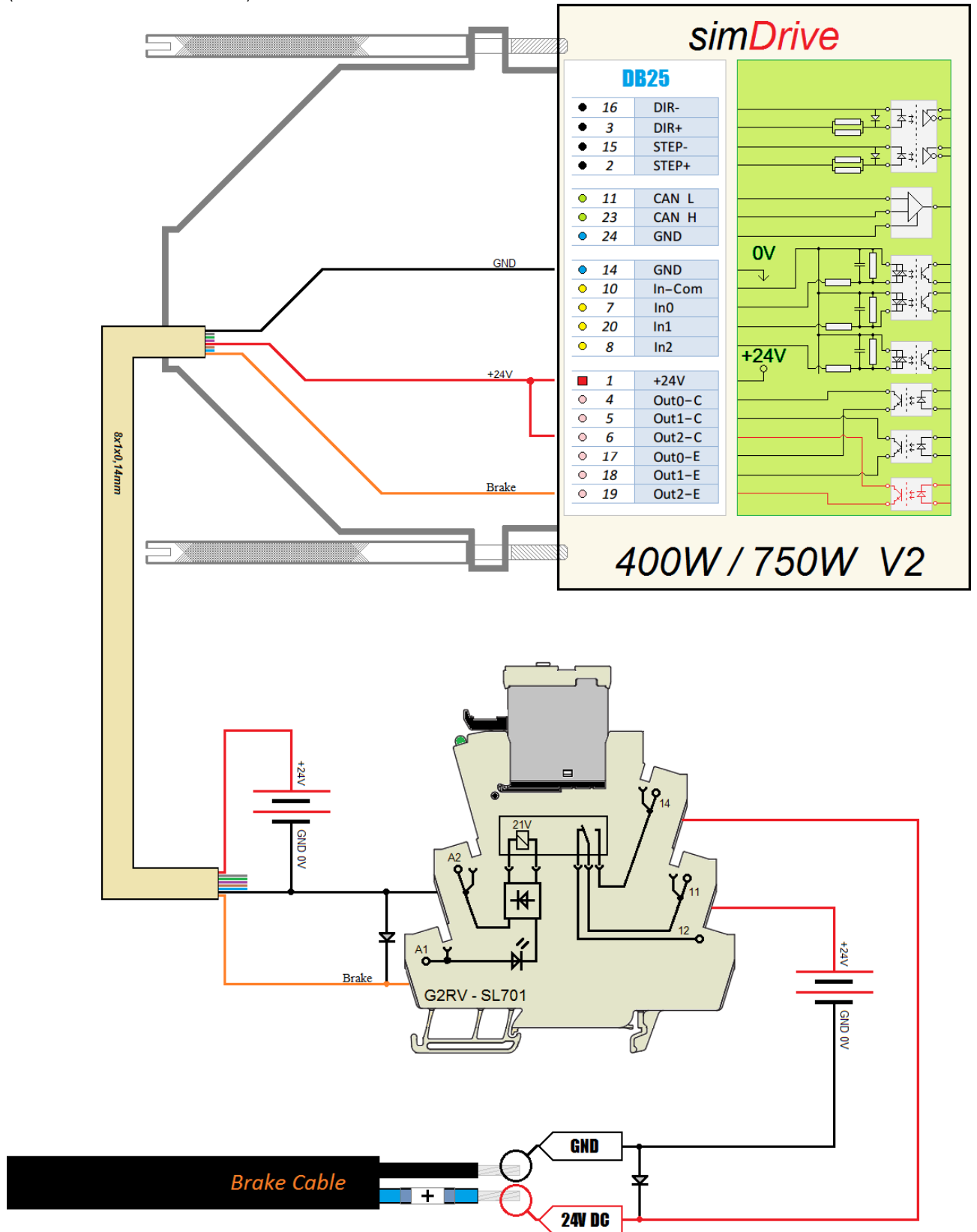

6. Encoder cable longer than 5m

Regardless of the length of the encoder cable you should always use shielded cable. The drawing for the encoder cable longer than 5m is exactly the same as for standard 5 m cable.

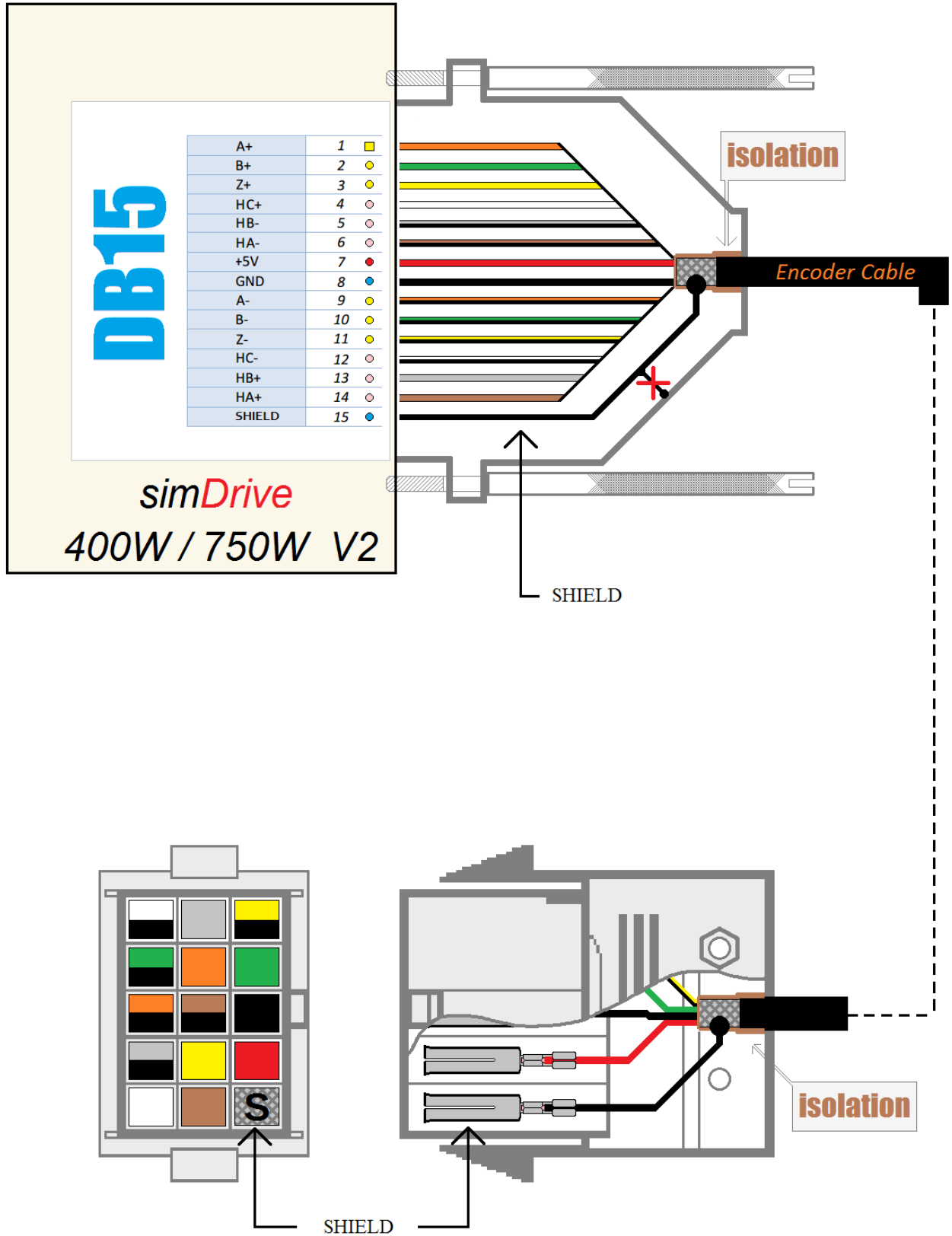

6.1 Shielding of an encoder cable longer than 5m

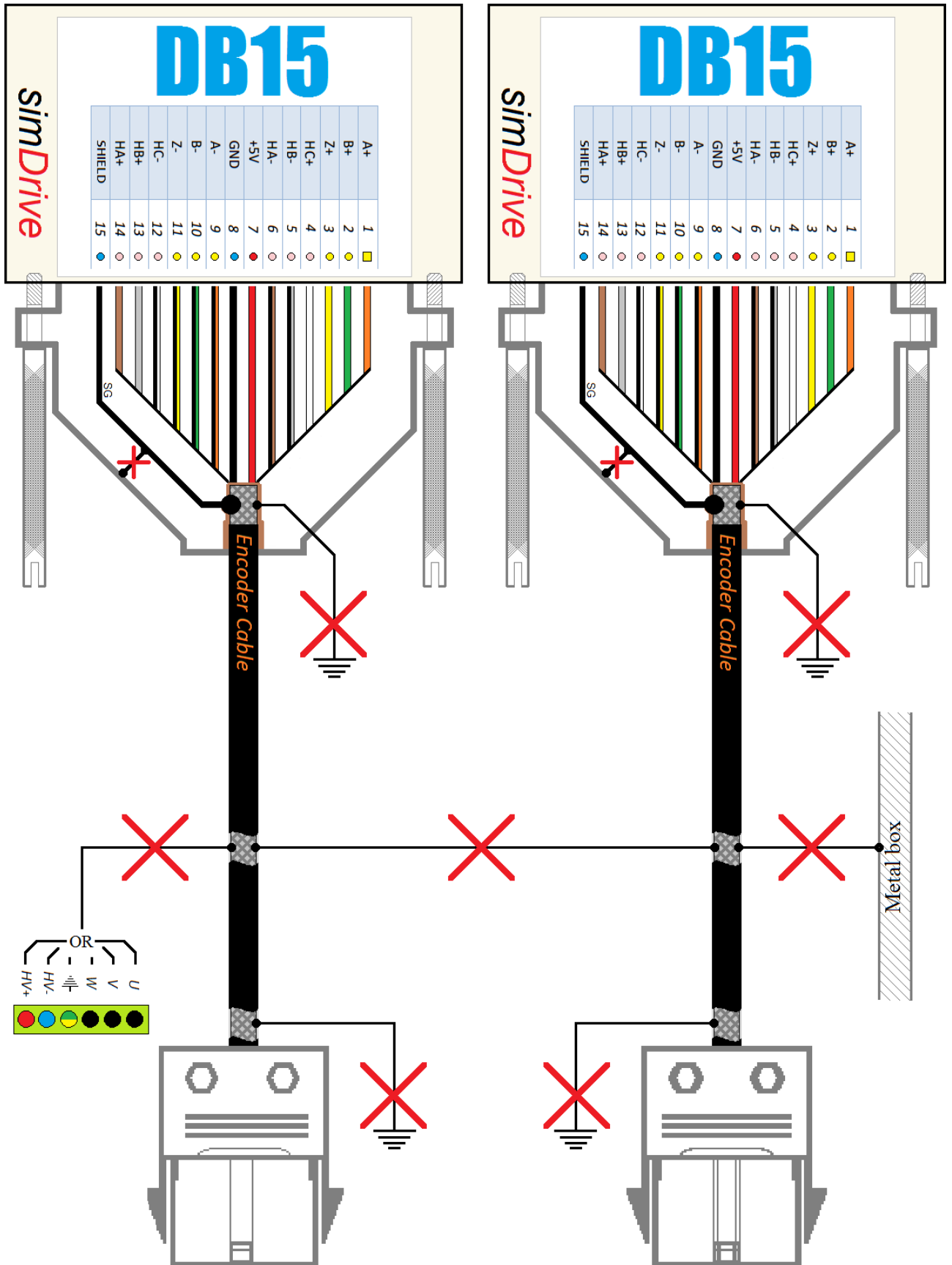

7. Power cable longer than 5m

It is recommended to use shielded power cables if longer than 5 meters. Using not shielded power cable may cause encoder signals noise even if they are actually shielded.

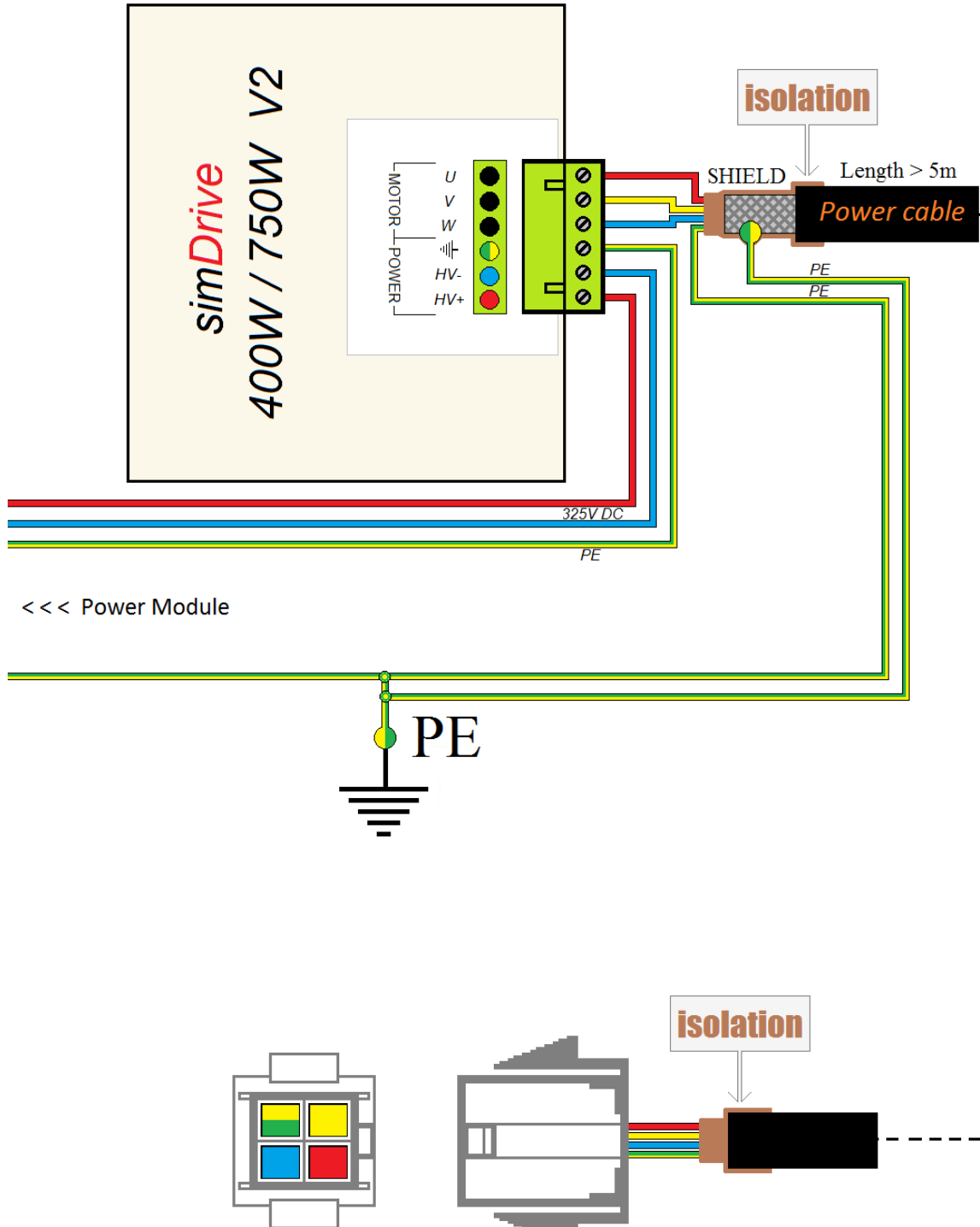

7.1 Shielding of a power cable longer than 5m

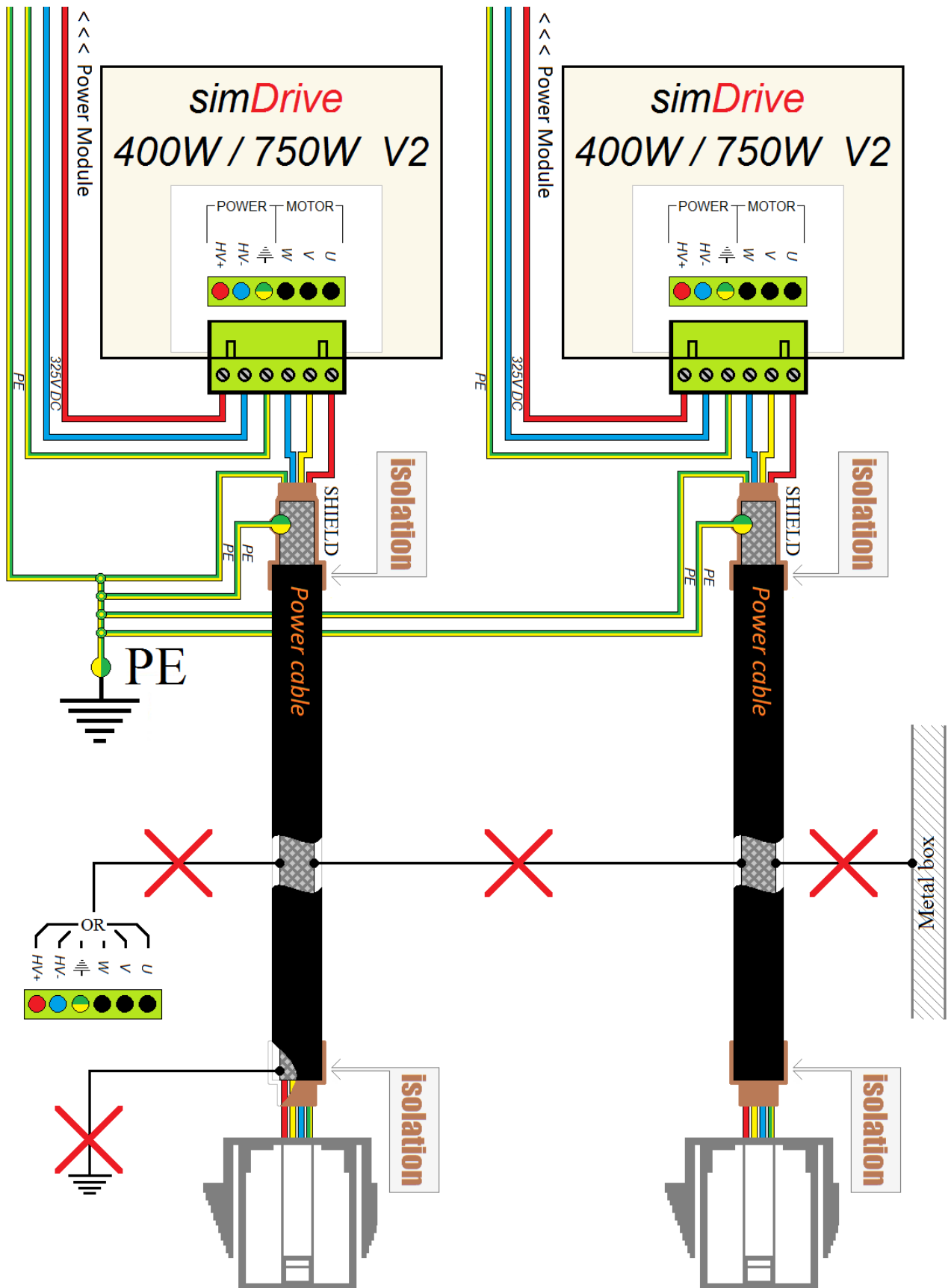

7.2 Power supply connection to simDrive when using a power cable longer than 5m

It is recommended to connect shields and PE wires of the power cables with separate wires to a main ground point. This solution will help you to reduce interference faster and more effectively.

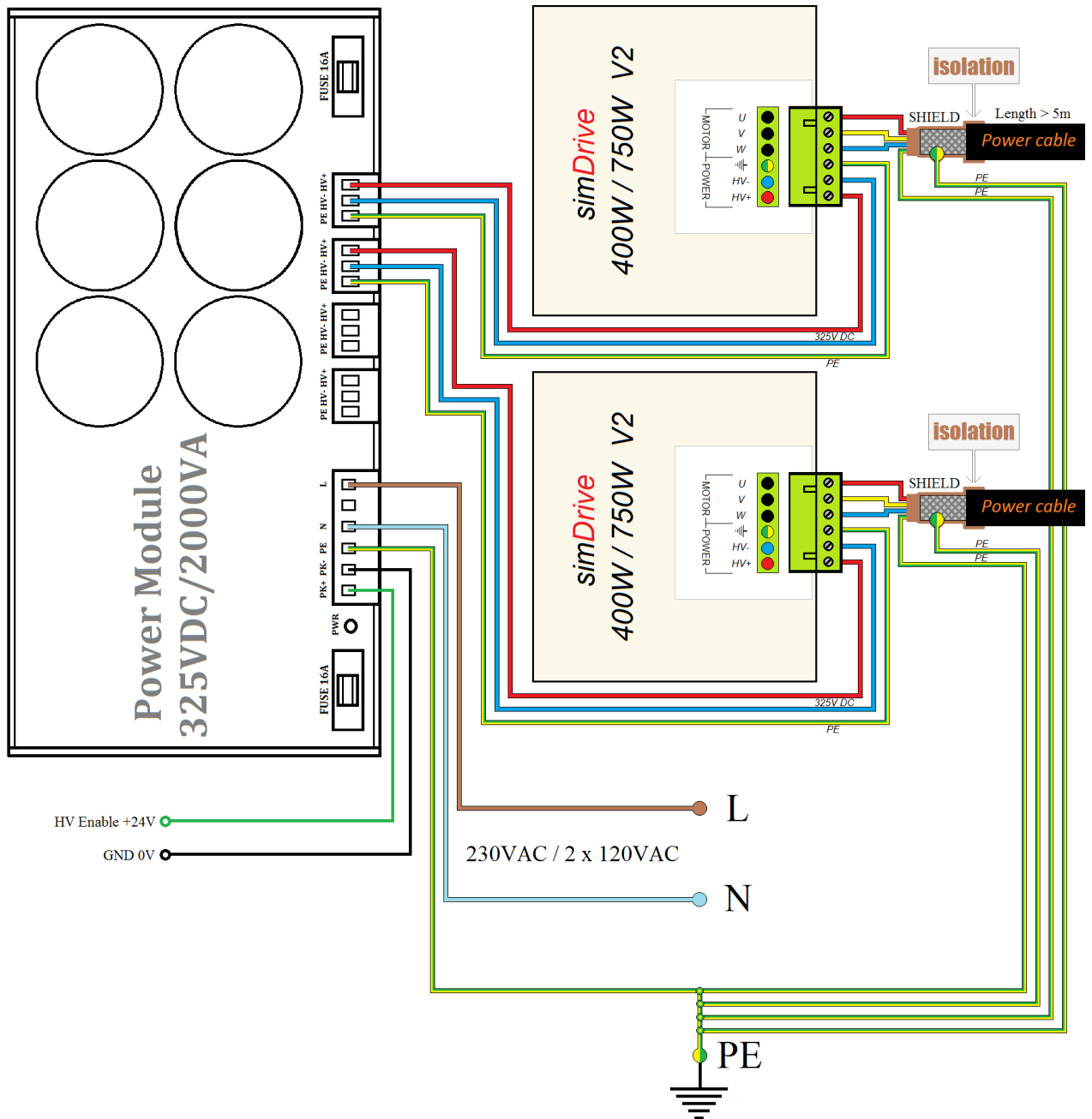

8. CAN bus

In the drawing below you can see several combinations of device connection to the CAN bus. Order of the devices in the CAN bus doesn't matter. It's important the shield retains continuity along the CAN bus and is connected to GND (0V) only from the motion controller side.

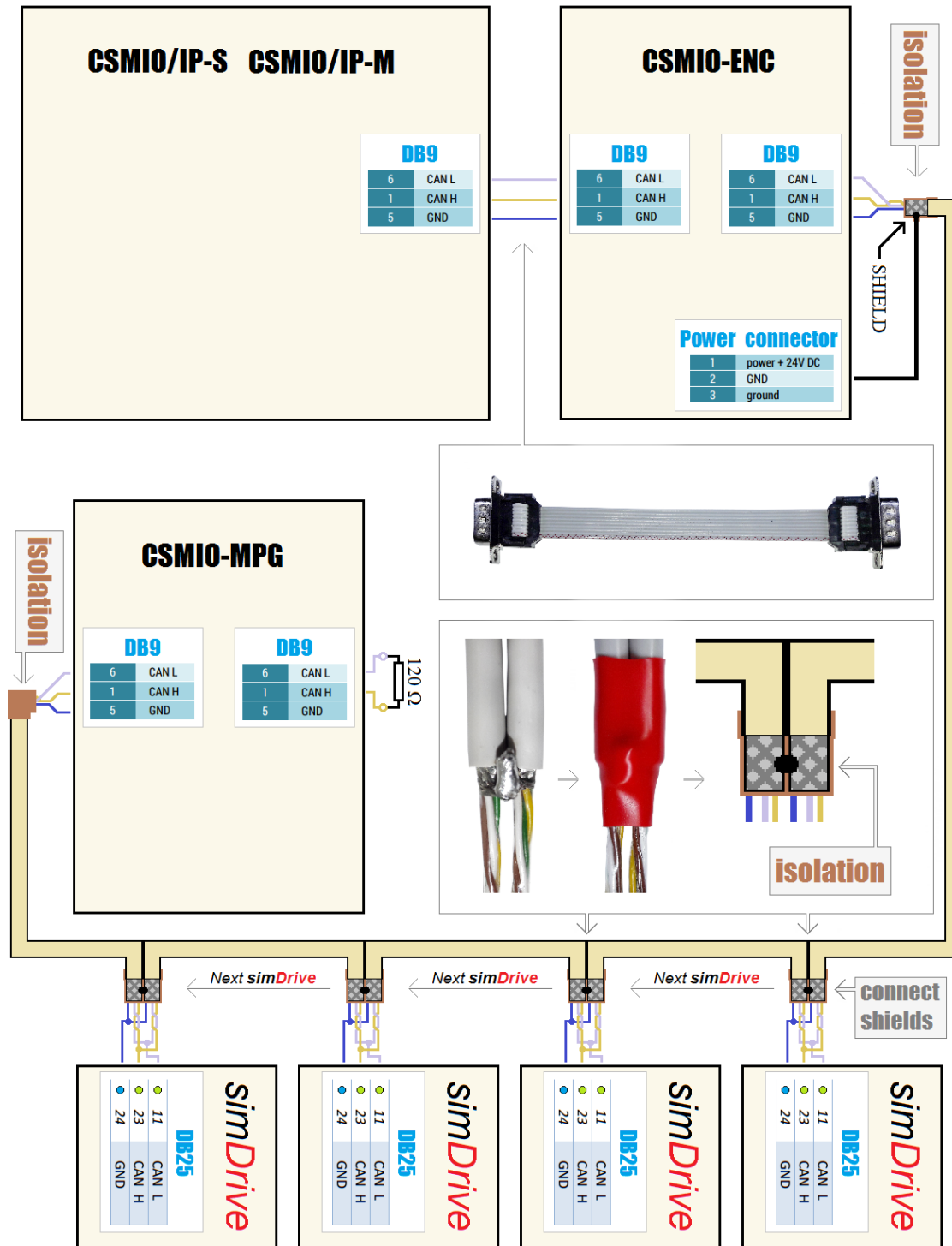

9. Terminals panel – not-shielded power cable.

If a machine is equipped with a panel with terminals you should remember that shield of an encoder cable and of a power cable run through the pin.

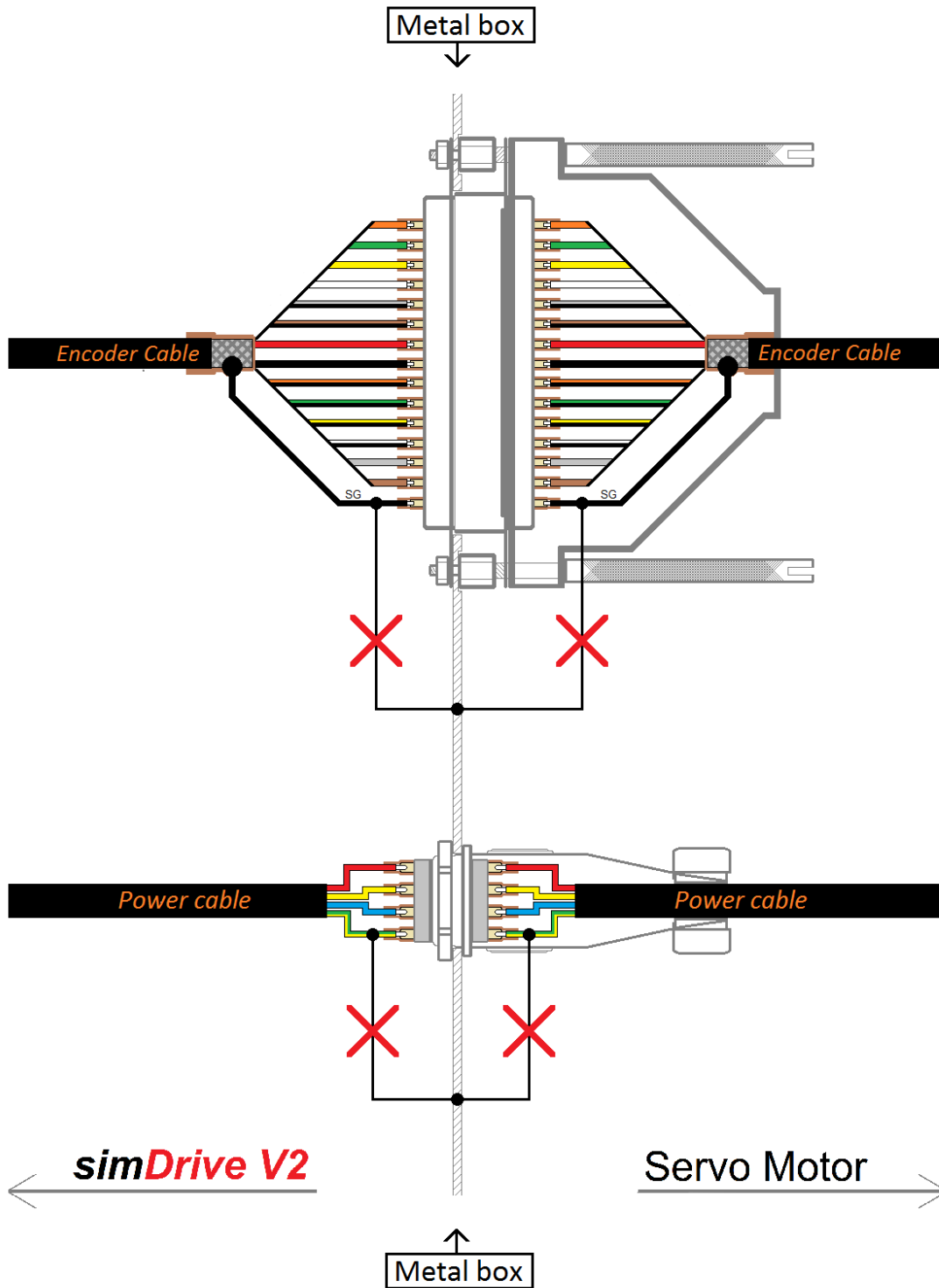

10. Terminals panel – shielded power cable.

If a machine is equipped with a panel with terminals, you should remember that shield of an encoder cable and shield and PE of a power cable should run through the pin.

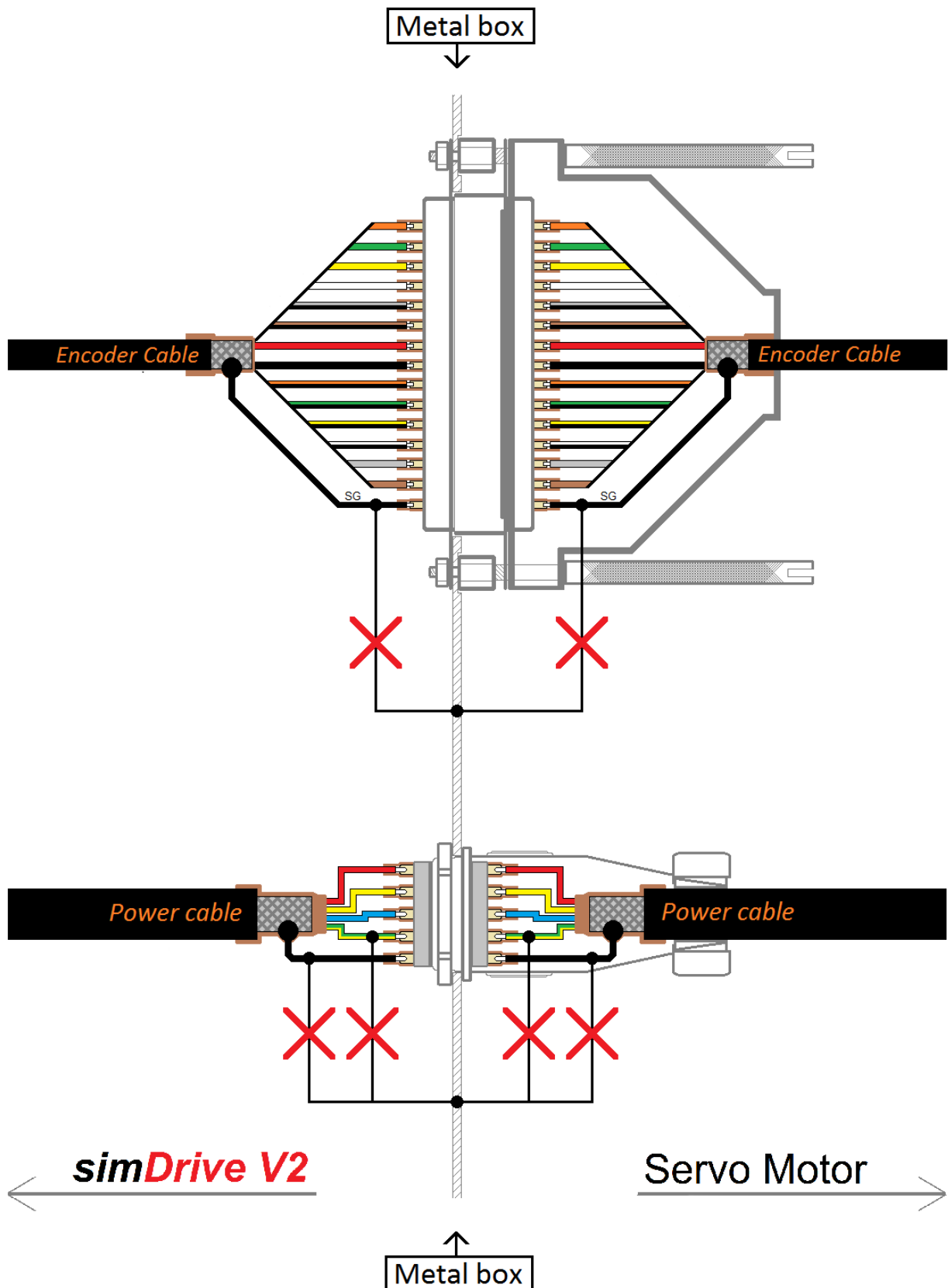

11. Accessories – simDrive

11.1 simDrive V2

To make the simDrive V2 installation processes faster and easier you can use special connectors for control signals such as step/dir, Servo Alarm, Servo Reset etc.

Attention!

PIN numbers on the connector are consistent with DB25 socket numbers.

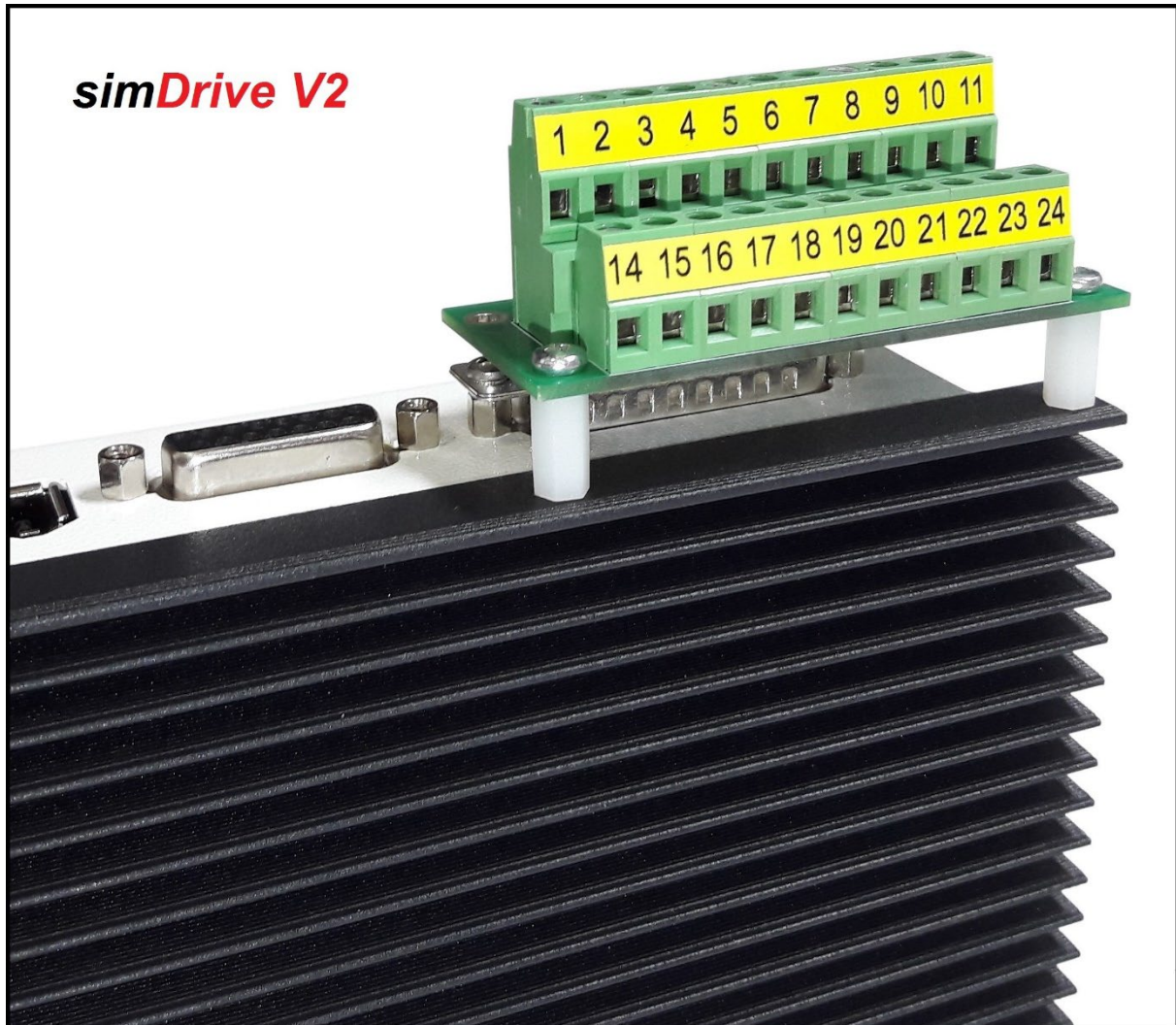

The connector is fastened directly to a simDrive V2 DB25 socket with spacer pins.